

## Thyristor Surge Suppressors (TSS) Data Sheet

### Description

DO-214AA Thyristor solid state protection thyristor protect telecommunications equipment such as modems, line cards, fax machines, and other CPE.

The LTPB3100C device is used to enable equipment to meet various regulatory requirements including GR 1089, ITU K.20, K.21 and K.45, IEC 60950, and TIA-968 (formerly known as FCC Part 68).

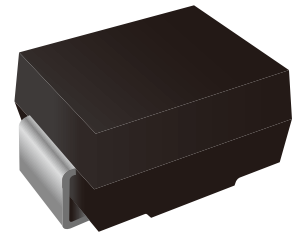

Functional Diagram

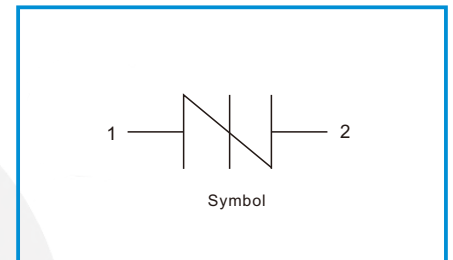

### Features

- Cannot be damaged by voltage
- Eliminate hysteresis and heat dissipation typically found with clamping devices
- Eliminate voltage overshoot caused by fast-rising transients
- Are non-degenerative
- Will not fatigue
- Have low capacitance, making them ideal for high-speed transmission equipment
- Meets MSL level 1, per J-STD-020

### Thermal Considerations

Parameter	Symbol	Value	Unit
Operating Junction Temperature	$T_J$	-40 to +150	$^{\circ}\text{C}$
Storage Temperature Range	$T_S$	-40 to +150	$^{\circ}\text{C}$
Junction to Ambient on printed circuit	$R_{\theta JA}$	90	$^{\circ}\text{C}/\text{W}$

## Electrical Parameters

Parameter	Definition
$V_{DRM}$	<b>Peak Off-state Voltage</b> – maximum voltage that can be applied while maintaining off state
$V_S$	<b>Switching Voltage</b> – maximum voltage prior to switching to on state
$V_T$	<b>On-state Voltage</b> – maximum voltage measured at rated on-state current
$I_{DRM}$	<b>Leakage Current</b> – maximum peak off-state current measured at $V_{DRM}$
$I_S$	<b>Switching Current</b> – maximum current required to switch to on state
$I_T$	<b>On-state Current</b> – maximum rated continuous on-state current
$I_H$	<b>Holding Current</b> – typical current required to maintain on state
$C_O$	<b>Off-state Capacitance</b> – typical capacitance measured in off state
$I_{PP}$	<b>Peak Pulse Current</b> – maximum rated peak impulse current
$I_{TSM}$	<b>Peak One-cycle Surge Current</b> – maximum rated one-cycle AC current
$di/dt$	<b>Rate of Rise of Current</b> – maximum rated value of the acceptable rate of rise in current over time

## Electrical Characteristics

Part Number	$V_{DRM}$ (V)	$V_S$ (V)	$V_T$ (V)	$I_{DRM}$ ( $\mu$ A)	$I_S$ (mA)	$I_T$ (A)	$I_H$ (mA)	$C_O$ (pF)	Marking
LTPB3100C	275	350	4	2	800	2.2	150	90	P31C

### Notes:

- All measurements are made at an ambient temperature of 25°C.  $I_{PP}$  applies to -40°C through +85°C temperature range.
- Off-state capacitance( $C_O$ ) is measured at 1 MHz with a 2V bias and is typical value.
- Rating Surge Voltage: 6KV,  $\pm 5$  times (10/700 $\mu$ s)

## Surge Ratings

$I_{PP}$ 2 $\times$ 10 $\mu$ s (A)	$I_{PP}$ 8 $\times$ 20 $\mu$ s (A)	$I_{PP}$ 10 $\times$ 160 $\mu$ s (A)	$I_{PP}$ 10 $\times$ 560 $\mu$ s (A)	$I_{PP}$ 10 $\times$ 1000 $\mu$ s (A)	$I_{TSM}$ 60Hz (A)	$di/dt$ (A/ $\mu$ s)
500	400	200	150	100	50	500

## Characteristics Curves

Figure 1. V-I Characteristics

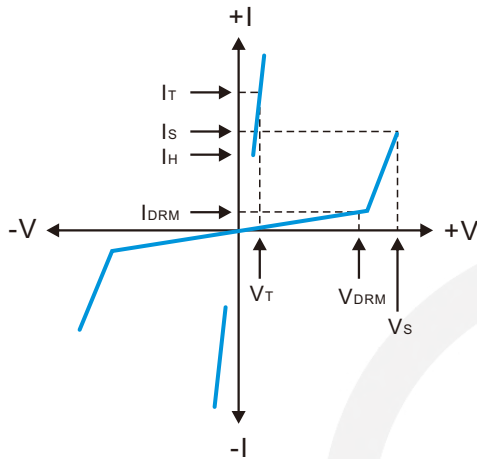

Figure 2.  $t_r \times t_d$  Pulse Wave-form

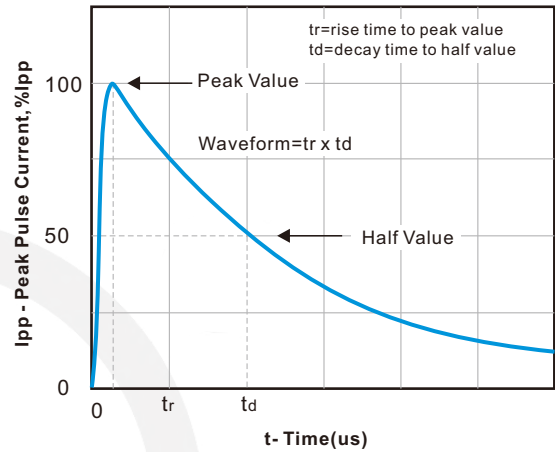

Figure 3. Normalized  $V_s$  Change versus Junction Temperature

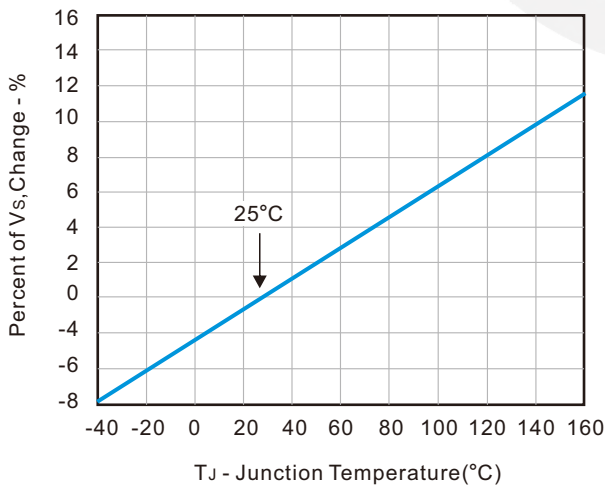
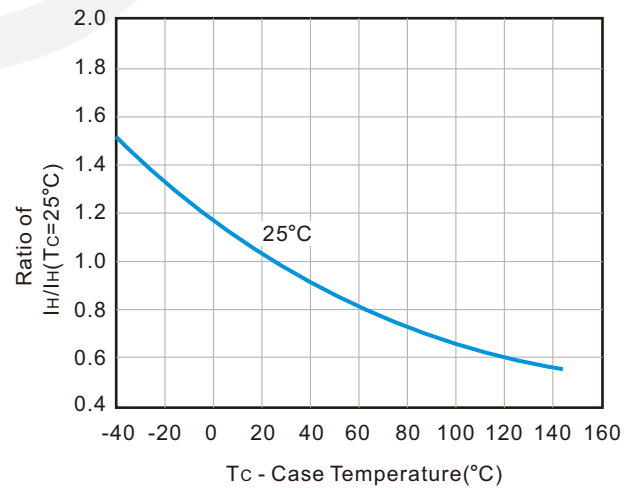
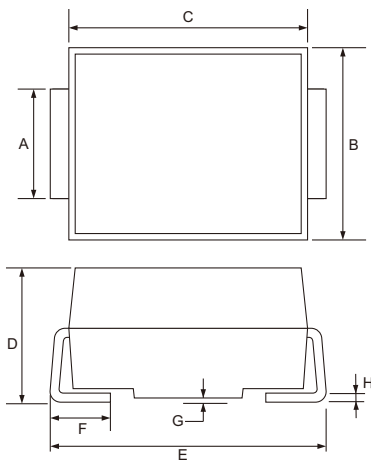

Figure 4. Normalized DC Holding Current versus Case Temperature



## SMB Package Outline



Unit: mm

SYMBOL	DIMENSIONS	
	MIN.	MAX.
A	1.90	2.20
B	3.30	3.94
C	4.05	4.75
D	2.13	2.65
E	5.08	5.59
F	0.76	1.52
G	0.203 TYP.	
H	0.15	0.31

## SMB Suggested Pad Layout

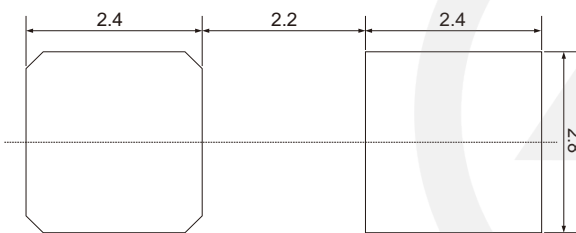

Note:

1. Controlling dimension: in millimeters.
2. General tolerance:  $\pm 0.05\text{mm}$
3. The pad layout is for reference purpose only.

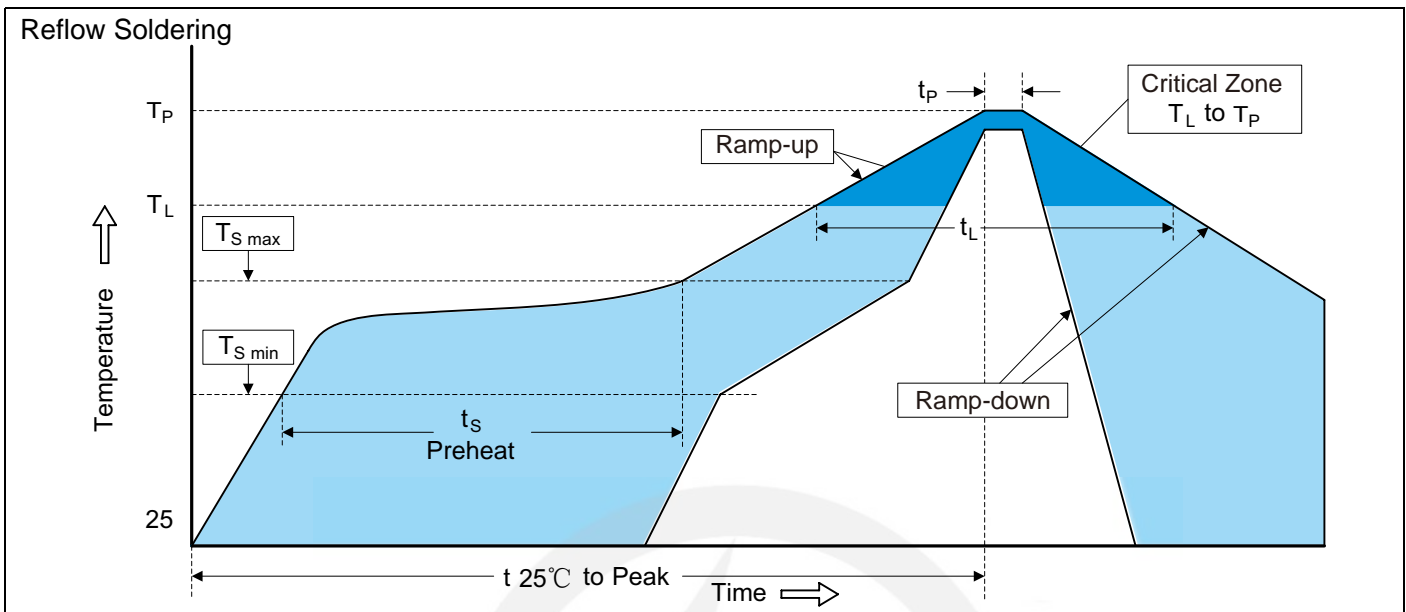
**Recommended Soldering Conditions**

**Recommended Conditions**

Profile Feature	Pb-Free Assembly
Average ramp-up rate ( $T_L$ to $T_P$ )	3°C/second max.
Preheat -Temperature Min ( $T_{S\ min}$ ) -Temperature Max ( $T_{S\ max}$ ) -Time (min to max) ( $t_s$ )	150°C 200°C 60-180 seconds
$T_{S\ max}$ to $T_L$ -Ramp-up Rate	3°C/second max.
Time maintained above: -Temperature ( $T_L$ ) -Time ( $t_L$ )	217°C 60-150 seconds
Peak Temperature ( $T_P$ )	260°C
Time within 5°C of actual Peak Temperature ( $t_P$ )	20-40 seconds
Ramp-down Rate	6°C/second max.
Time 25°C to Peak Temperature	8 minutes max.

**Packaging**

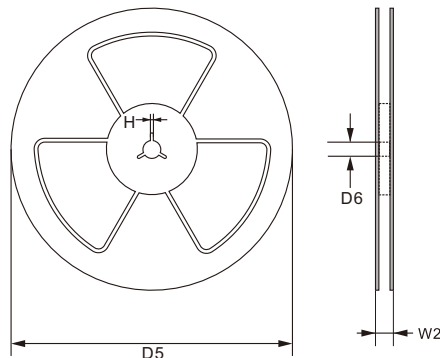
13" Reel

 D5       $\Phi 330.0 \pm 2.0$ 

 D6       $\Phi 13.5 \pm 0.5$ 

 H       $2.5 \pm 1.0$ 

 W2       $16.0 \pm 2.0$ 

Quantity: 3000PCS